

Lightweight Drums

Tight head drums 215 liter (US 55 gall)
 optimal drainable for the transport of liquid hazardous materials



09.11 E

Advantages

- UN homologation for fluid dangerous goods
- Compliance with EC 94/62 EC
- Coatings also comply with EC 1895/2005, AP 96 (5) EC, BAG, BGA, FDA, EU 90.128/EEC
- ODD version enable the drum to empty leaving less residue than a standard drum, due to optimum drainage configuration in the head
- When drum is empty materials can be recycled without any problems
- EN 15593:2008 Management of hygiene in the production of packagings for food stuffs

Construction

- Body overlapped welded, top/bottom seamed to body with injected sealing compound
- 2" and 3/4" bungs in the lid
- Different hoops and corrugations possible
- Standard hoop can be reduced to facilitate containerisation

Materials

- mild steel DC01

Surface treatment

- lacquered
- Interior plain steel or lacquer lining for chemicals or food stuff
- exactly suitable for your products
- On line silk screening on body and top available

Remarks

- Designed for optimum strength and volume

Quality management

- ISO 9001: 2000



Technical information



09.11 E

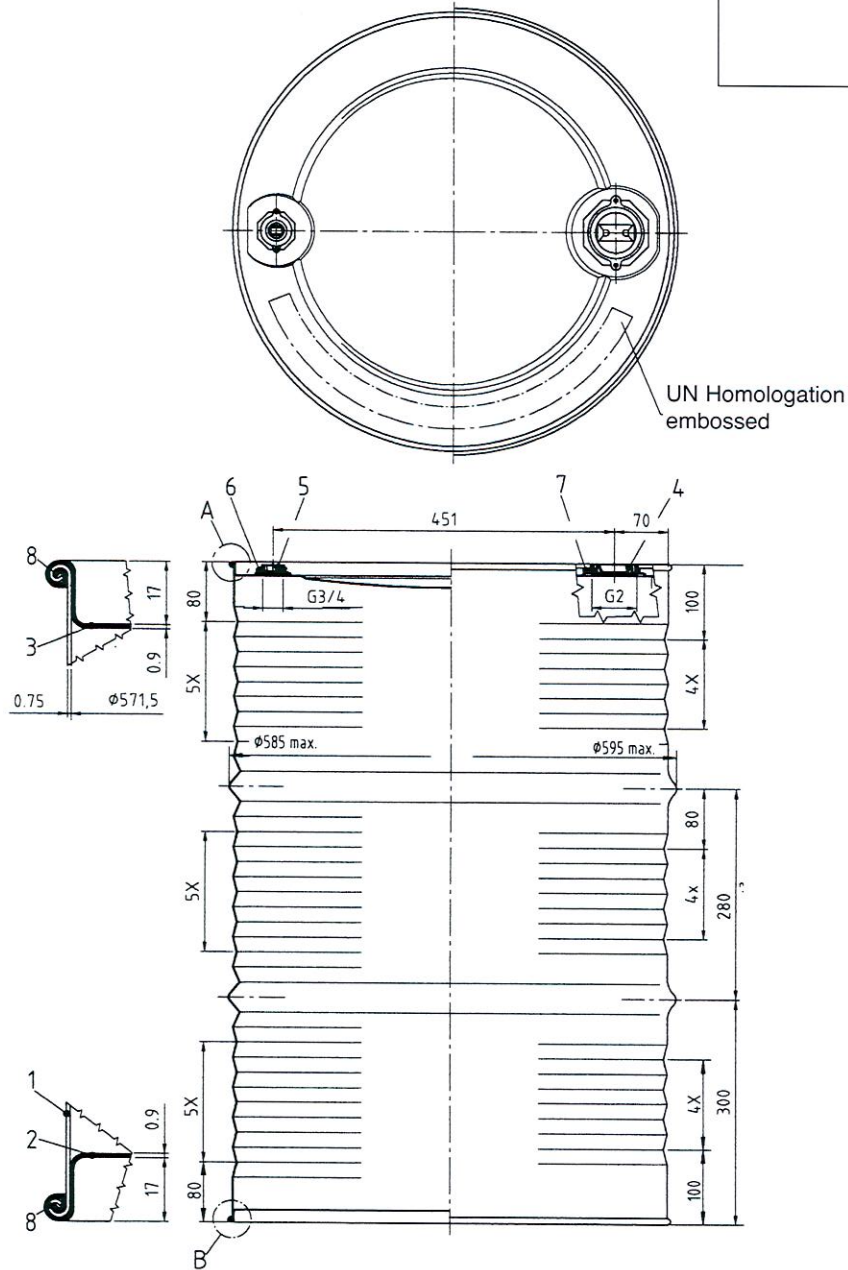

Capacity Ltr.	Diameter mm	Thickness mm Bottom/Body/Top	UN Marking	Remarks
215	571,5	0,90 / 0,75 / 0,90	UN 1A1/X/250/.../CH/EGI-4205244-M UN 1A1/Y1.8/250/.../CH/EGI-4205244-M	14,6 kg

Other sizes and design upon request

For more information please contact us and ask for detailed technical documentation



Müller Ltd Packaging
Tramstrasse 20
CH-4142 Münchenstein

Phone: +41(0)61/4161200
Fax: +41(0)61/4161222
Internet: www.muellerdrums.com
E-mail: info@muellerdrums.com